

GENERAL CARE AND MAINTENANCE

The 711 telephone does not require any regular maintenance.
To clean the telephone wipe with a damp cloth.

Do not use any abrasive cleaners on the telephone as this may cause the product to become discoloured.

Distributed by: -

DAC Limited
214a Lomeshaye Business Village
Turner Road
Nelson, Lancashire, UK
BB9 7DR
T +44 (0) 1282 447000
F +44 (0) 845 2801915

www.daclimited.co.uk

DAC LIMITED



USER GUIDE Vandal Resistant Telephones 711 Autodial Telephone range



APPROVED FACILITIES

Any other usage will invalidate the approval of the apparatus if as a result it then ceases to comply with the standards against which the approval was granted.

Connection is affected by plugging in to the appropriate line socket. If your telephone connection is not fitted with new style sockets contact your approved telephone installer or the telephone network supplier.

If this method of connection is inadequate because, for example, the telephone is to be mounted outside where new sockets are not intended to be used, arrange for your telephone network supplier to directly connect the instrument.

The telephone should operate correctly when connected to most compatible PBXs, including those that use secondary dialling tone. However, it cannot be guaranteed that the apparatus will operate under all possible conditions of connection. Any cases of difficulty should be referred in the first instance to your local supplier of the instrument

This apparatus is intended to be internally accessible for installation purposes only to authorized personnel and must be installed such that user access is prevented. Correct fitting and installation are mandatory as failure to prevent such user access will invalidate any approval given to this apparatus.

TO STORE AN AUTODIAL NUMBER.

Insert the keypad that is supplied with the telephone into connector marked **CN13**.

To store a number in a one button autodialler.

Press the button on the front panel to go off hook. Press the key marked **PG** on the rear of the telephone followed by **M1**. Then using the keypad supplied dial the number that needs to be stored followed by **PG** on the back of the telephone. To clear down press the key marked **ON HK**.

To store a number in a two button autodialler.

Follow the above instructions for button one. Button two is a repeat of button one, however press **M2** to allocate the autodial number to button 2.

When programming is complete remove the external keypad and store safely. The memories on the 711 will not be lost if the line is disconnected

USE OF THE 711

To make a call press the desired autodial button, you will hear dial tone, and then the number will be dialled.

When the telephone is off hook the red LED will be illuminated. The call will clear down on detection of the line disconnection tones or after a preset time if using the timer option (see setting up the 711 features).

To answer a call when the 711 is ringing, press any button.

SETTING UP THE 711 FEATURES.

Volume.

To adjust the volume of the speaker use the V+ and V- keys on the rear of the phone. The volume once set will remain at the user set level until it is re adjusted.

Call termination settings.

Call termination can be by pressing the off button on the front of the telephone, by tone detection or preset timer.

Timer

To select preset timer place the link provided on the header marked TMR TYPE on to the NRM setting, then select a duration for maximum call length by adjusting the potentiometer marked HK TIME (variable between 1 -10 minutes). Function can be disabled by turning the potentiometer fully anti clockwise.

Tone detection

To select the tone detection option place the link provided on the header marked TMR TYPE on to the NRM setting. This will automatically clear the line at the end of a call by detecting the tones on the line.

Dialling modes

The telephone has selectable links for the different dialling and recall modes. These are selected by placing the links onto the relevant headers at the bottom of the board.

Dial modes

MF dialling- Take the link and place it onto the header marked DIAL placing it on the MF link.

LD dialling- Take the link and place it onto the header marked DIAL placing it on the LD link.

Recall modes

TBR recall- Take the link and place it onto the header marked BREAK placing it on the TBR link.

ER recall- Take the link and place it onto the header marked BREAK placing it on the ER link.

INSTALLATION

The following information is provided for use by the approved installer or telephone network supplier only. The RA711 telephone can be either wall mounted or top-of-pole mounted. Wall mounting can be surface, flush or inset into the wall. Various electrical options are available as defined under the Electrical Connections section. Make sure that these are set correctly before finally fitting the unit to the back box.

Wall Flush Installation

1. Produce hole in wall 285mm high 120mm wide 60mm deep.
2. Use size 8 or 10 screws with rawplugs (4 off) to fix back box into wall, with cut-out at the bottom
3. Connect the cabling, Use a 2.5mm socket-head key for the M4 bolts, through the 4 small holes in the front plate, to fit the telephone unit to the back-box. Start each screw by turning several rotations at a time until all 4 screws are secure. To remove the telephone from the box, reverse the procedure.
4. Use any suitable silicone waterproofing sealant (such as Unibond Waterproof Flexible Frame Sealant) to seal to the wall. Leave a 12mm to 13mm (0.5") gap at the bottom for drainage.

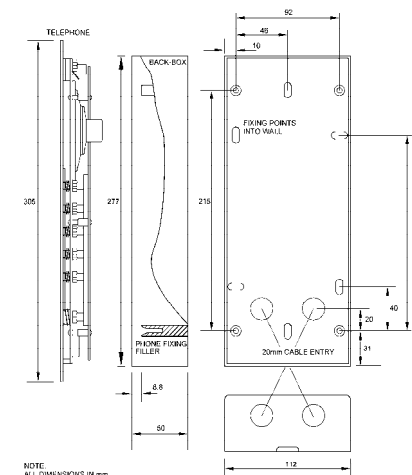

Wall Surface Installation

1. Fix the surface mounting back box to the wall, with cut-out at the bottom, using size 8 or 10 screws with rawplugs (4 off).
2. Connect the cabling, as detailed under Electrical Connections, and then fit to the back box (as described under Wall Flush Installation, item 3).
3. Use any suitable silicone waterproofing sealant (such as Unibond Waterproof Flexible Frame Sealant) to seal to the back box. Leave a 12mm to 13mm (0.5") gap at the bottom for drainage.

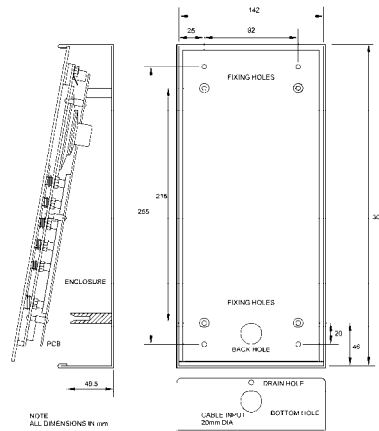

Top-of-pole Installation

1. Place the top-of-pole mounting over the top of the pole.
2. Tighten the grub screws to secure the mounting.
3. Fix the surface mounting back-box to the top-of-pole mounting with the screws provided.
4. Connect the cabling, as detailed under Electrical Connections, and then fit to the back-box (as described under Wall Flush Installation, item 3).

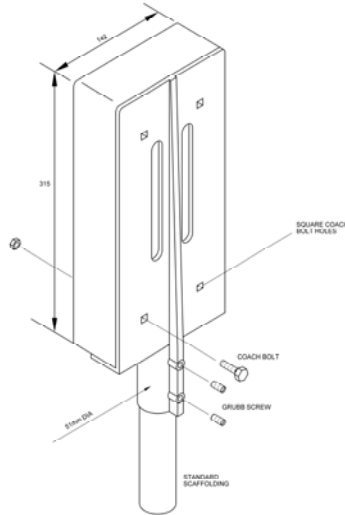

ELECTRICAL INSTALLATION

Line Terminal Connections and Selections

The number of telephones that can be connected to a direct exchange line or PBX extension is limited by the ringer equivalence number (REN) of all the telephones connected, this should not exceed a total value of 4.

The REN value of this telephone is 1. In case of doubt consult your telephone supplier.

The Terminal block mounted at the back of the unit is labelled as follows: -

- A. Line (A)
- ER. Earth when using Earth Recall
- B. Line (B)

Connect the telephone line to the wires marked A and B. If you are to use Earth Recall then also connect the earth wire to the terminal marked ER.

Once the line is connected please allow 30 seconds for the phone to completely power up before trying to use it. If the phone does not power up you can also press the small button labelled 'BOOT', located on the rear of the phone near to the bottom of the Circuit board.